

COLOR: _____
 CORNER GUARD: _____
 COLOR TO BE SELECTED FROM ONE OF C/S STANDARD COLORS.

QTY. REQ'D	UNIT HEIGHT

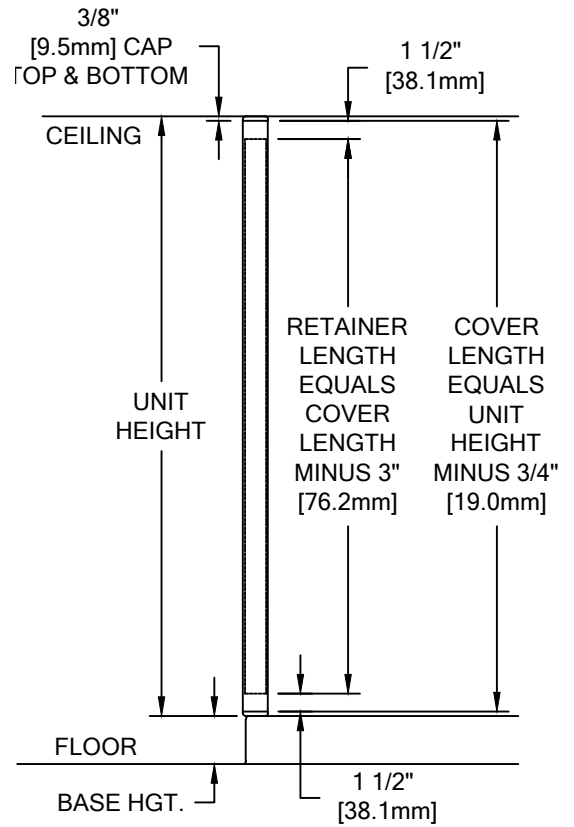
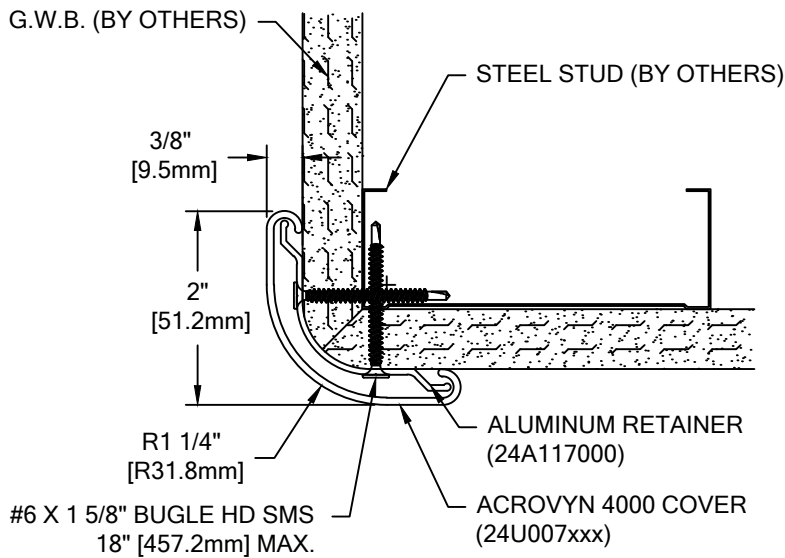

SURFACE MOUNTED GUARD
 AT FULL HEIGHT ELEVATION

SSM-10N ACROVYN 4000

WALL CONDITION	SPECIFIED FASTENER	DRILL DIAMETERS		C/S PART NUMBER
		WALL	RETAINER	
STEEL STUD/GYPSUM WALL	#6 X 1 5/8" BUGLE HEAD SMS	N/A	7/64"	90H079002
WOOD STUD/GYPSUM WALL	#6 X 1 5/8" BUGLE HEAD SMS	N/A	7/64"	90H079002
CONCRETE/CONC. BLOCK	AF-6 PLASTIC ANCHOR #10 X 1 1/2" PHILLIPS PAN HEAD SMS	15/64"	9/32"	90H039004 90H189002

 Unit 6, 26-32 Cosgrove Road Enfield NSW 2136 P: 1300 272 602 E: sales@c-sgroup.com.au © Copyright 2016 Construction Specialties, Inc.	PROJECT:	REVISION:
	JOB NO.:	F&F:
	CUSTOMER:	
	REP:	DATE:
	DRAWN BY:	SHEET NO: