

SURFACE MOUNTED CORNER GUARDS

PLEASE READ

PLEASE READ THESE INSTRUCTIONS THOROUGHLY PRIOR TO BEGINNING THE SURFACE MOUNTED CORNER GUARD INSTALLATION!

THIS INSTRUCTION SHEET IS INTENDED TO PROVIDE A SPECIFIC GUIDE TO FOLLOW FOR THE INSTALLATION OF THIS SURFACE MOUNTED CORNER GUARD. CONTAINED WITHIN IS THE TECHNICAL INFORMATION AND INSTALLATION TECHNIQUES REQUIRED TO COMPLETE AN EFFICIENT, NEAT AND LONG-LASTING INSTALLATION.

INSPECT ALL MATERIALS FOR DAMAGE OR MISSING PARTS. IF YOU DISCOVER DAMAGED OR MISSING MATERIALS, PLEASE NOTIFY CUSTOMER SERVICE ON 1300 272 602.

SURFACE MOUNTED CORNER GUARD MUST BE INSTALLED IN ACCORDANCE WITH THESE INSTRUCTIONS! FAILURE TO FOLLOW THESE INSTRUCTIONS MAY VOID ANY PRODUCT WARRANTIES AND RESULT IN AN UNSUCCESSFUL INSTALLATION. FOR SPECIFIC QUESTIONS REGARDING THE INSTALLATION OF THIS SURFACE MOUNTED CORNER GUARD PLEASE CALL CUSTOMER SERVICE ON 1300 272 602 OR EMAIL SALES@C-SGROUP.COM.AU

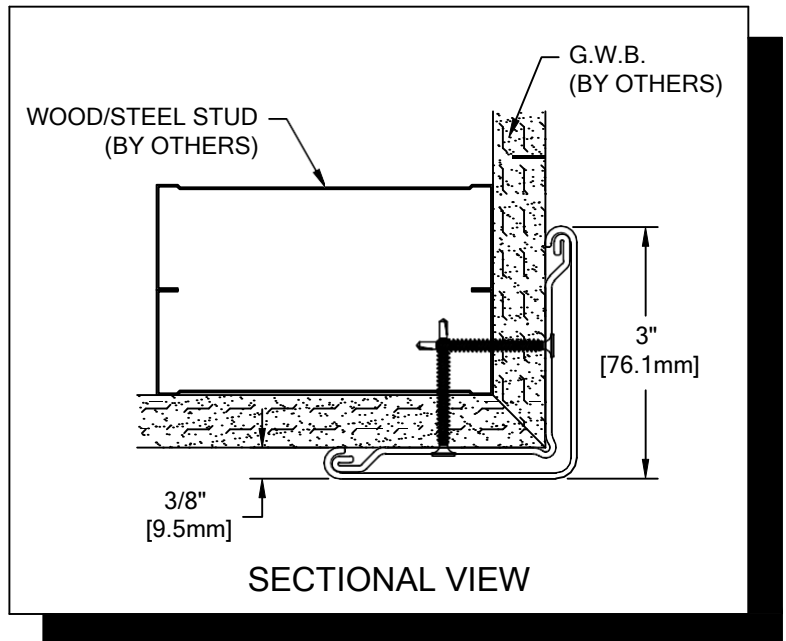

IMPORTANT NOTES

1. ALL LINEAL MATERIAL TO BE SUPPLIED IN STOCK LENGTHS. ALUMINUM AND ACROVYN IN LENGTHS UP TO 20'-0". THIS MATERIAL IS TO BE FIELD CUT USING QUALITY EQUIPMENT TO INSURE THAT ALL CUTS ARE SQUARE. WHEN CUTTING MATERIAL SECTIONS, C/S RECOMMENDS USING AN 80-100 TOOTH CARBIDE TIPPED SAW BLADE OR EQUIVALENT, TO MINIMIZE CHIPPING AND MAINTAIN JOINT ALIGNMENT.
2. ALL DIMENSIONS ARE TYPICAL.
3. FOR DRYWALL/PLASTER WALL CONSTRUCTION, IT IS RECOMMENDED FOR FASTENERS TO BE ENGAGED INTO METAL/WOOD STUDS TO MAINTAIN MAXIMUM PULLOUT STRENGTH.
4. MATERIAL MUST REACH 65°F MIN. TO 75°F MAX. 24 HOURS PRIOR TO INSTALLATION. THIS IS ESSENTIAL TO MINIMIZE EXPANSION AND CONTRACTION OF MATERIAL.
5. FASTENERS ARE TO BE STAGGERED BY 2" [50.8mm] TO AVOID INTERFERENCE AND SPALLING OF THE MASONRY WALL.
6. FOR MORE INFORMATION ON SURFACE MOUNTED CORNER GUARDS SEE OUR WEBSITE AT www.c-sgroup.com.au

SURFACE MOUNTED CORNER GUARDS

COMPONENTS & WALL FASTENERS

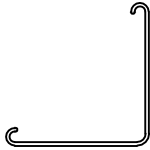

SM-20N ACROVYN COVER
(24U002xxx)
ACROVYN CHAMELEON COVER
(24U634xxx)

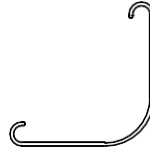

SM-10N ACROVYN COVER
(24U130xxx)
ACROVYN CHAMELEON COVER
(24U963xxx)

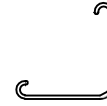

SSM-20N ACROVYN COVER
(24U004xxx)
ACROVYN CHAMELEON COVER
(24U622xxx)

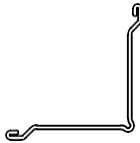

SM-20N ALUMINUM RETAINER
(24A339000)
REGRIND RETAINER
(24U026000)

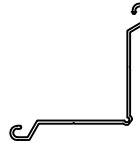

SM-10N ALUMINUM RETAINER
(24A341000)



SSM-20N ALUMINUM RETAINER
(24A340000)
REGRIND RETAINER
(24U030000)



SM-20N END CAP - (24I068xxx, SHOWN)
SM-20N CHAMELEON CAP - (24I646xxx)
SM-10N END CAP - (24I126xxx)
SM-10N CHAMELEON CAP - (24I993xxx)
SSM-20N END CAP - (24I070xxx)
SSM-20N CHAMELEON CAP - (24I622xxx)

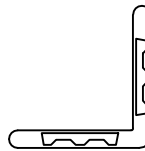

OPTIONAL ACCENT REVEAL
SM-20N - (24I099xxx, SHOWN)
SSM-20N - (24I100xxx)

WALL CONDITION	SPECIFIED FASTENER	DRILL DIAMETERS		C/S PART NUMBER
		WALL	RETAINER	
STEEL STUD/GYPSUM WALL WOOD STUD/GYPSUM WALL	#6 X 1 5/8" BUGLE HEAD SHEET METAL SCREW	N/A	1/8"	90H079002
CONCRETE/CONCRETE BLOCK	AF-6 PLASTIC ANCHOR #10 X 1 1/2" PHILLIPS PAN HEAD SMS	1/4"	9/32"	90H039004 90H189002
CONCRETE/CONCRETE BLOCK END CAP ATTACHMENT	1/8" BLIND RIVET #8 SAE FLAT WASHER STEEL PLATED	N/A	5/32"	90H111002 90H010003

SURFACE MOUNTED CORNER GUARDS

LAYOUT VIEWS

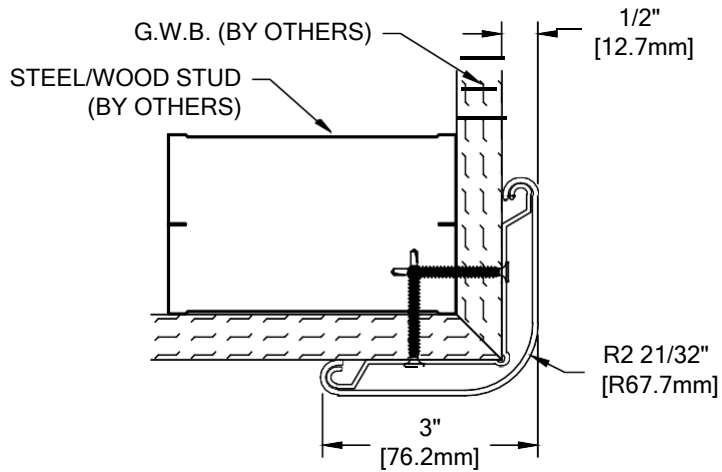

SM-10N

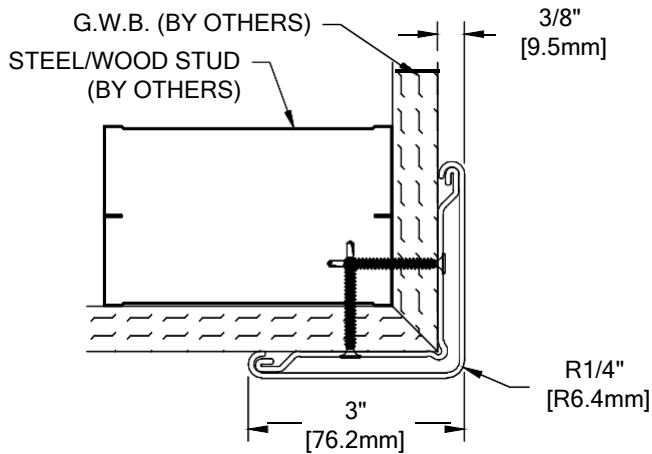

SM-20N

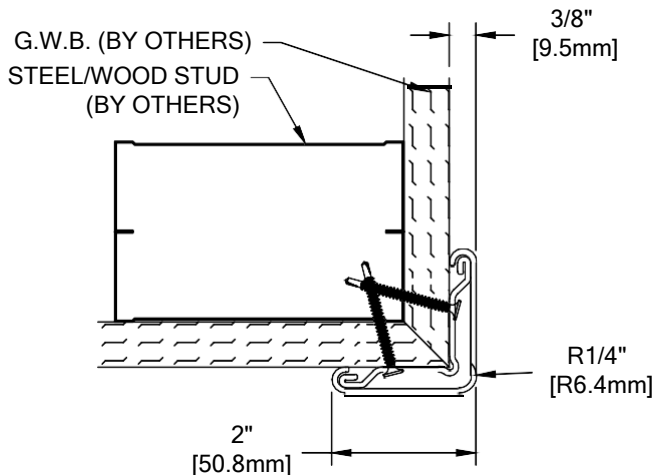

SSM-20N

STANDARD DEDUCTIONS

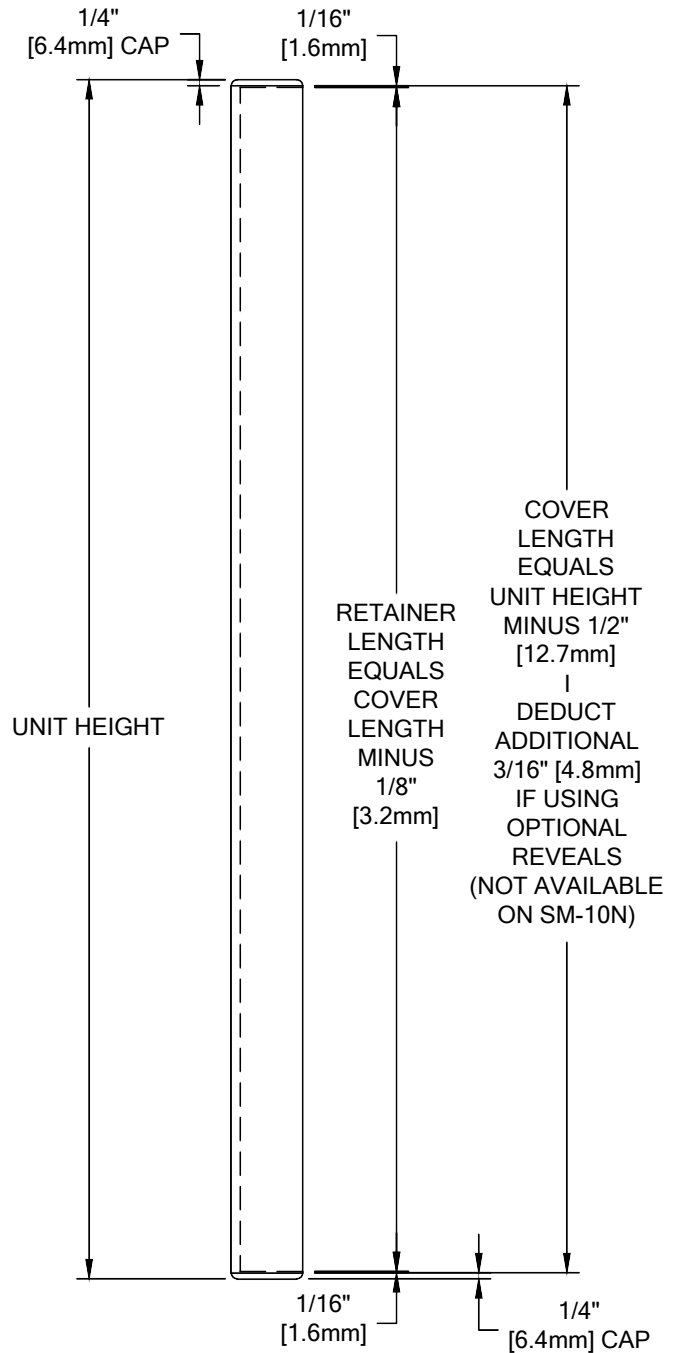

SURFACE MOUNTED CORNER GUARDS

TYPICAL ASSEMBLY

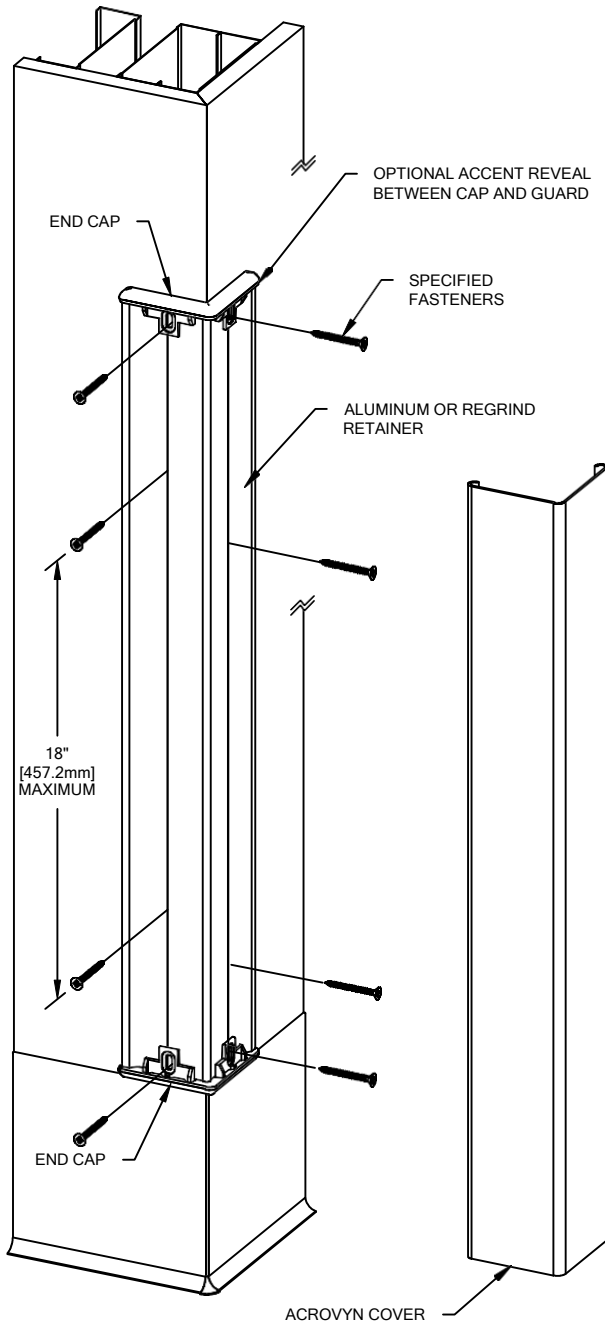

DRYWALL/
PLASTER
APPLICATION

1. LOCATE AND INSTALL C/S CORNER GUARDS IN ACCORDANCE WITH ARCHITECTURAL DRAWINGS AND SPECIFICATIONS. WHEN REQUIRED, C/S SHOP DRAWINGS SHOULD BE USED IN CONJUNCTION WITH THESE DOCUMENTS.
2. LAY OUT THE WORK TO BE COMPLETED, INCLUDING COMPONENT PARTS, AT EACH LOCATION TO RECEIVE CORNER GUARDS AS INDICATED BY THE C/S SHOP DRAWINGS. SPOT CHECK THE MATERIAL FOR ANY DAMAGE INCURRED DURING SHIPPING AND/OR HANDLING AT THE JOB SITE.
3. CUT THE ALUMINUM OR REGRIND RETAINER TO LENGTH USING THE REQUIRED DEDUCTIONS (REFERENCE STANDARD DEDUCTIONS).

NOTE: IT IS RECOMMENDED THAT ACROVYN COVER AND ALUMINUM RETAINER BE CUT WITH AN 80-100 TOOTH CARBIDE TIPPED SAW BLADE OR EQUIVALENT.

4. INSTALL RETAINER 1/4" [6.4mm] ABOVE COVE BASE OR FINISH FLOOR USING THE REQUIRED FASTENERS AS NOTED ON PAGE 2.
5. INSTALL THE BOTTOM END CAP BY ABUTTING THE CAP WITH THE END OF THE RETAINER, ALLOWING THE FLANGES TO OVERLAP THE END OF THE RETAINER AS SHOWN. SECURE INTO POSITION USING THE SPECIFIED FASTENERS.

NOTE: TO AID IN LOCATING THE END CAPS CORRECTLY, CUT A 4" [101.6mm] SECTION OF COVER FROM SCRAP AND SNAP IT ON THE RETAINER. LOCATE THE CAP SO IT ALIGNS FLUSH WITH TOP AND BOTTOM OF THE COVER.

NOTE: FOR MASONRY INSTALLATIONS: ATTACH THE END CAPS TO THE RETAINER FIRST, THEN ATTACH THE ASSEMBLED UNIT TO THE SUBSTRATE. (SEE CONCRETE/BLOCK DETAIL)

6. REPEAT THE PROCEDURE TO INSTALL THE TOP END CAP.
7. CUT THE ACROVYN COVER TO THE PROPER LENGTH USING THE REQUIRED DEDUCTIONS (REFERENCE STANDARD DEDUCTIONS).
8. FINISH INSTALLATION BY SNAPPING THE ACROVYN COVER ONTO THE RETAINER.

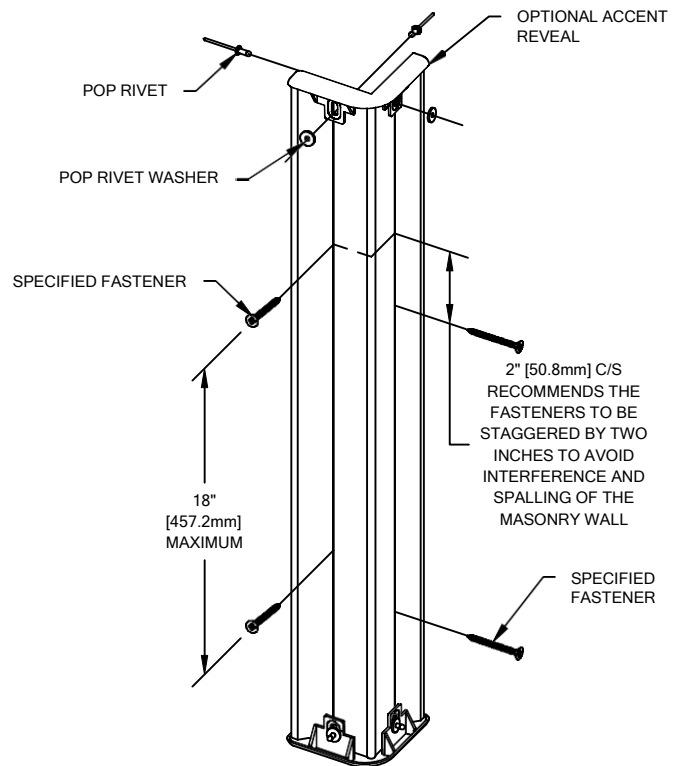

CONCRETE/
C.M.U. WALL
APPLICATION

06/09/15