

FLUSH MOUNTED CORNER GUARDS

PLEASE READ

PLEASE READ THESE INSTRUCTIONS THOROUGHLY PRIOR TO BEGINNING THE FLUSH MOUNTED CORNER GUARD INSTALLATION!

THIS INSTRUCTION SHEET IS INTENDED TO PROVIDE A SPECIFIC GUIDE TO FOLLOW FOR THE INSTALLATION OF THIS FLUSH MOUNTED CORNER GUARD. CONTAINED WITHIN IS THE TECHNICAL INFORMATION AND INSTALLATION TECHNIQUES REQUIRED TO COMPLETE AN EFFICIENT, NEAT AND LONG-LASTING INSTALLATION.

INSPECT ALL MATERIALS FOR DAMAGE OR MISSING PARTS. IF YOU DISCOVER DAMAGED OR MISSING MATERIALS, PLEASE NOTIFY CUSTOMER SERVICE ON 1300 272 602.

FLUSH MOUNTED CORNER GUARD MUST BE INSTALLED IN ACCORDANCE WITH THESE INSTRUCTIONS! FAILURE TO FOLLOW THESE INSTRUCTIONS MAY VOID ANY PRODUCT WARRANTIES AND RESULT IN AN UNSUCCESSFUL INSTALLATION. FOR SPECIFIC QUESTIONS REGARDING THE INSTALLATION OF THIS FLUSH MOUNTED CORNER GUARD PLEASE CALL CUSTOMER SERVICE ON 1300 272 602 OR EMAIL SALES@C-SGROUP.COM.AU

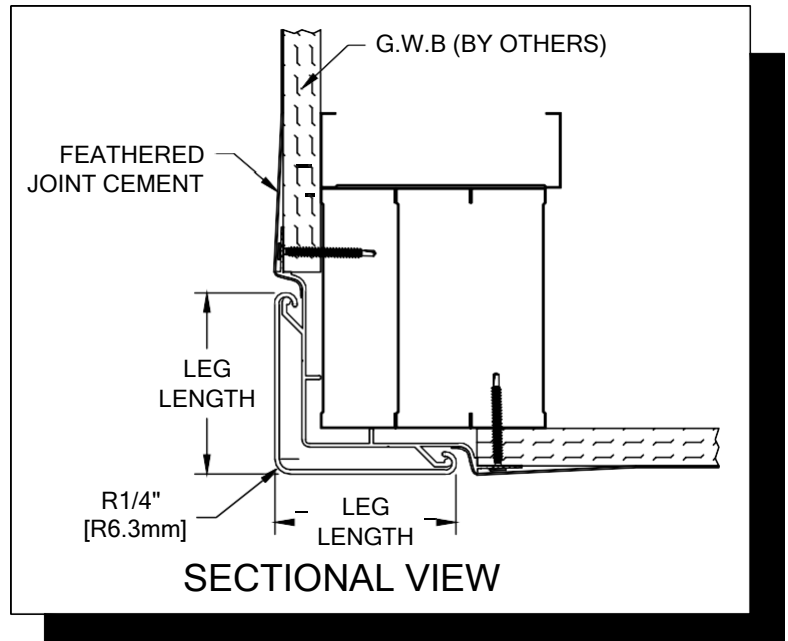

IMPORTANT NOTES

1. ALL MATERIAL TO BE SUPPLIED IN STOCK LENGTHS. ALUMINUM RETAINER AND ACROVYN COVERS IN LENGTHS UP TO 20'-0". THIS MATERIAL IS TO BE FIELD CUT USING QUALITY EQUIPMENT TO ENSURE THAT ALL CUTS ARE SQUARE. WHEN CUTTING MATERIAL SECTIONS, CS RECOMMENDS USING AN 80-100 TOOTH CARBIDE TIPPED SAW BLADE OR EQUIVALENT, TO MINIMIZE CHIPPING AND MAINTAIN JOINT ALIGNMENT.
2. ALL DIMENSIONS ARE TYPICAL.
3. FOR DRYWALL/PLASTER WALL CONSTRUCTION, IT IS RECOMMENDED FOR FASTENERS TO BE ENGAGED INTO METAL/WOOD STUDS TO MAINTAIN MAXIMUM PULLOUT STRENGTH. IF DURING INSTALLATION YOU ENCOUNTER SPECIAL WALL CONDITIONS THAT DO NOT ALLOW FOR DIRECT ATTACHMENT TO THE STUDS PLEASE CONSULT THE LOCAL AUTHORITY HAVING JURISDICTION.
4. MATERIAL MUST REACH 65°F MIN. TO 75°F MAX. 24 HOURS PRIOR TO INSTALLATION. THIS IS ESSENTIAL TO MINIMIZE EXPANSION AND CONTRACTION OF MATERIAL.
5. DUE TO 1 1/4" [31.8mm] NOSE RADIUS IT IS NOT RECOMMENDED TO INSTALL FS-10N, FS-10MN, OR SFS-10N AT PARTIAL HEIGHT.
6. FOR MORE INFORMATION ON FLUSH MOUNTED CORNER GUARDS SEE OUR WEBSITE AT www.c-sgroup.com.au

FLUSH MOUNTED CORNER GUARDS

SECTIONAL VIEW

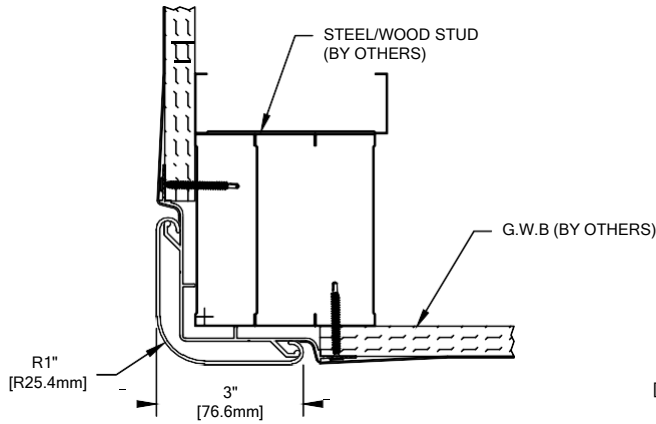

FS-10N

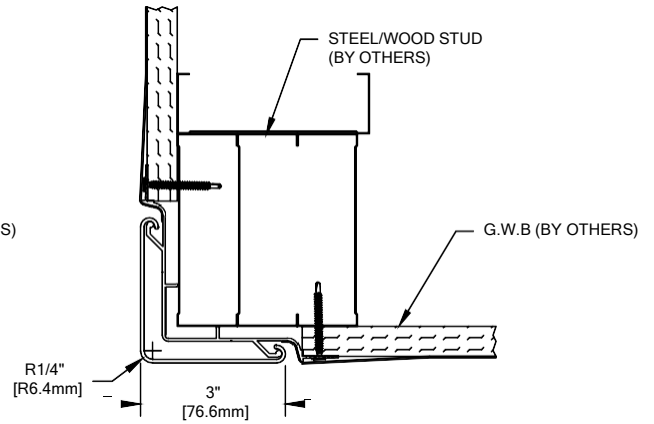

FS-20N

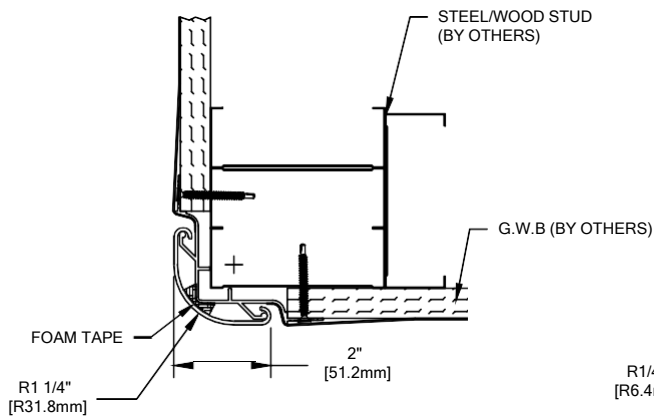

SFS-10N

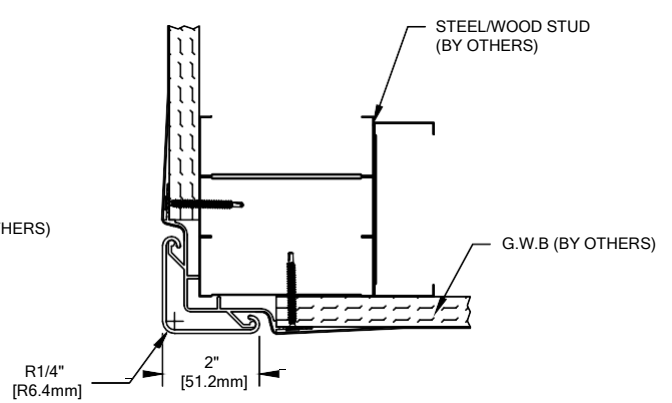

SFS-20N

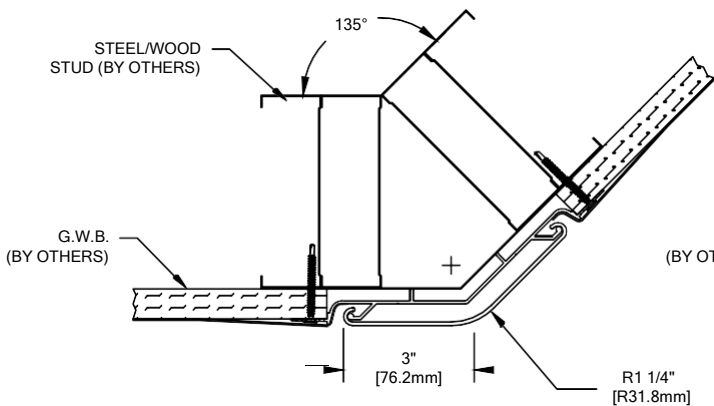

FS-10MN

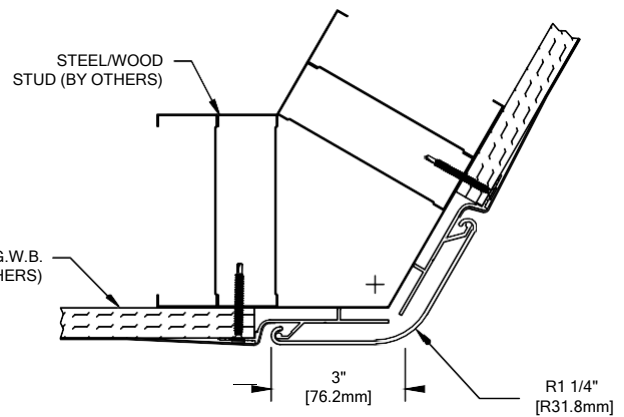

FS-10N MOD

- RETAINER IS SPLIT FOR ANGLES LESS THAN 78° OR GREATER THAN 154°
- RETAINER IS FACTORY MODIFIED FOR ALL OTHER ANGLES (EXCLUDING 90°)

FLUSH MOUNTED CORNER GUARDS

COMPONENTS & WALL FASTENERS

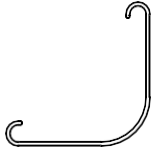

FS-10N/FS-10MN ACROVYN COVER
(24U130xxx)
ACROVYN CHAMELEON COVER
(24U963xxx)

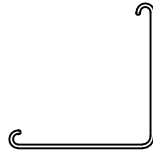

FS-20N ACROVYN COVER
(24U002xxx)
ACROVYN CHAMELEON COVER
(24U634xxx)

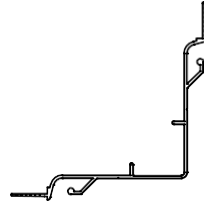

FS-10N/FS-20N
ALUMINUM RETAINER
1/2" DRYWALL (24A159000)
5/8" DRYWALL (24A166000)

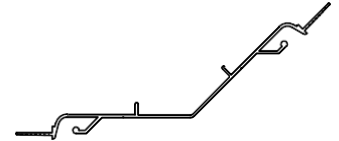

FS-10MN
ALUMINUM RETAINER
1/2" DRYWALL (24A162000)
5/8" DRYWALL (24A168000)
(SEE SECTION ON PAGE 2 IF WALL IS
AN ANGLE OTHER THAN 135°)



SFS-10N ACROVYN COVER
(24U007xxx)
ACROVYN CHAMELEON COVER
(24U676xxx)

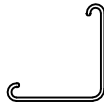

SFS-20N ACROVYN COVER
(24U004xxx)
ACROVYN CHAMELEON COVER
(24U622xxx)

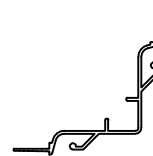

SFS-10N/SFS-20N
ALUMINUM RETAINER
1/2" DRYWALL (24A160000)
5/8" DRYWALL (24A167000)

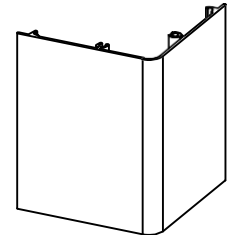

4" ALUMINUM BASE
(24F008000-FS10N)
(24F010000-FS10MN)
(24F009000-FS20N)
(24F011000-SFS10N)
(24F012000-SFS20N)

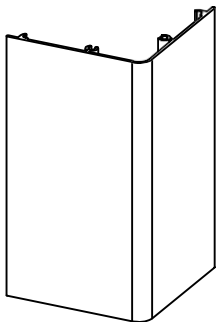

6" ALUMINUM BASE
(24F145000-FS10N)
(24F149000-FS10MN)
(24F146000-FS20N)
(24F147000-SFS10N)
(24F144000-SFS20N)

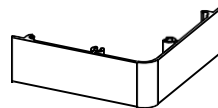

1" ALUMINUM
CLOSURE CAP
(24F094000-FS10N)
(24F096000-FS10MN)
(24F062000-FS20N)
(24F093000-SFS10N)
(24F063000-SFS20N)

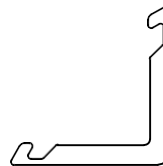

GASKET
(24M009000-FS10N)
(24M018000-FS10MN)
(24M010000-FS20N)
(24M011000-SFS10N)
(24M012000-SFS20N)



3/4" FOAM TAPE
SFS-10N ONLY
(90M008002C)

WALL CONDITION	SPECIFIED FASTENER	DRILL DIAMETERS		CS PART NUMBER
		WALL	RETAINER	
STEEL STUD/GYPSUM WALL WOOD STUD/GYPSUM WALL	#6 X 1 5/8" BUGLE HEAD SMS	N/A	N/A	90H079002

FLUSH MOUNTED CORNER GUARDS

LAYOUT VIEW

STANDARD DEDUCTIONS

NOTE:
DUE TO THE NOSE RADIUS, IT IS NOT RECOMMENDED TO INSTALL FS-10N, FS-10MN, OR SFS-10N AT PARTIAL HEIGHT.

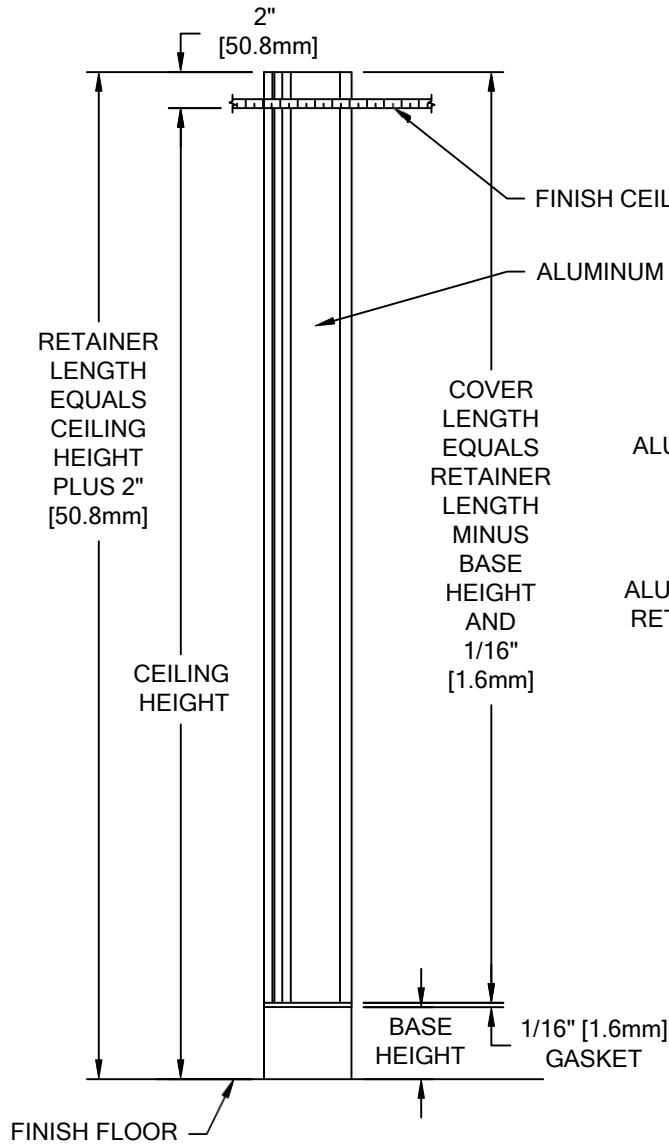

FULL HEIGHT

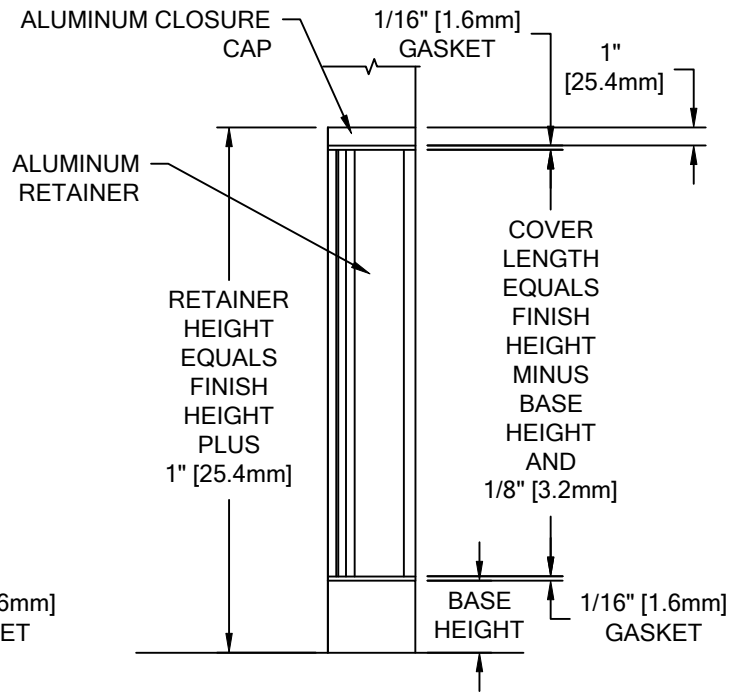

PARTIAL HEIGHT

FLUSH MOUNTED CORNER GUARDS

TYPICAL ASSEMBLY

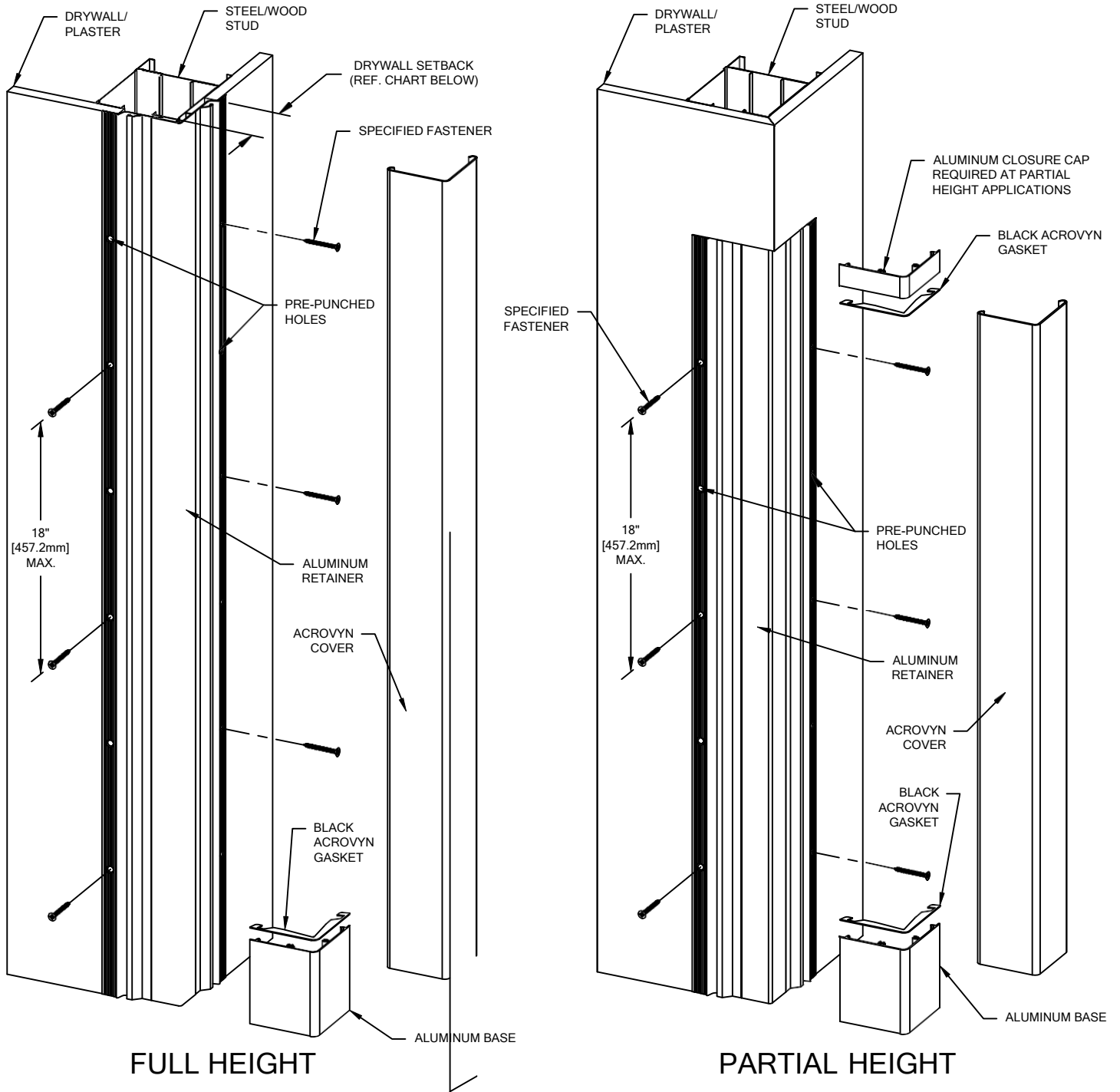

DRYWALL SETBACK CHART

	FS-10N	FS-10MN	FS-20N	SFS-10N	SFS-20N
1/2" DRYWALL	2 11/16" [68.3mm]	2 13/16" [71.4mm]	2 11/16" [68.3mm]	1 3/4" [43.8mm]	1 3/4" [43.8mm]
5/8" DRYWALL	2 5/8" [66.7mm]	2 13/16" [71.4mm]	2 5/8" [66.7mm]	1 5/8" [41.3mm]	1 5/8" [41.3mm]

FLUSH MOUNTED CORNER GUARDS

TYPICAL ASSEMBLY

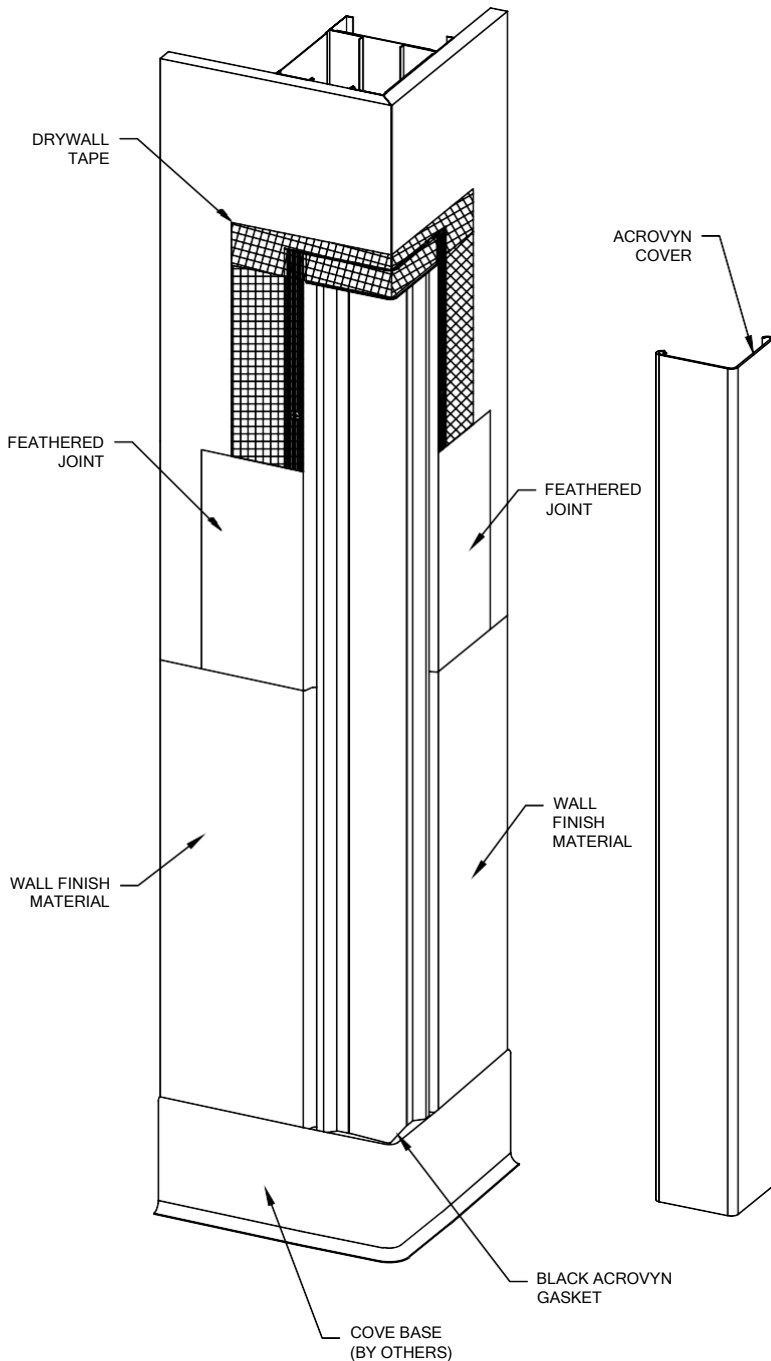

1. WHEN INSTALLING THE GYPSUM BOARD OR PLASTER, CONSULT THE CHART ON PAGE 5 TO DETERMINE THE SETBACK DISTANCE TO PROVIDE A SNUG FIT WHEN THE RETAINER IS INSTALLED.

NOTE: FOR ODD-ANGLE CONDITIONS DRY FIT ALUMINUM BASE WITH ALUMINUM RETAINERS TO AID IN DETERMINING DRYWALL SETBACK AND PROPERLY POSITION RETAINERS ON CORNER OF WALL. IF WALL IS LESS THAN 78° OR GREATER THAN 154°, ALUMINUM RETAINERS ARE SPLIT INTO (2) PIECES.

2. ALIGN EACH RETAINER WITH THE CORNER AND SECURE EACH LEG THROUGH THE WALL INTO METAL/WOOD STUDS USING THE SPECIFIED FASTENERS. MAKE SURE THE RETAINER REMAINS PLUMB WITH THE FINISH FLOOR.
3. INSERT ALUMINUM BASE CLOSURE AT THE BASE OF THE RETAINER AND SECURE THE ACROVYN GASKET ON TOP BY REMOVING THE PROTECTIVE COVERING TO EXPOSE THE TRANSFER ADHESIVE. ALIGN GASKET WITH OUTSIDE EDGE.

NOTE: GASKETS FOR FS-10N MOD CORNER GUARDS ARE TO BE FIELD MITERED.

4. A 1" [25.4mm] CLOSURE CAP IS TO BE INSTALLED AT TOP OF RETAINER ON PARTIAL HEIGHT GUARDS FOLLOWING PROCEDURES SIMILAR TO STEP 3.
5. APPLY 2" [50.8mm] JOINT TAPE ALONG THE EDGE OF THE DRYWALL AND THE ALUMINUM RETAINER WITH INTEGRATED CORNER BEAD. FINISH THE INSTALLATION BY APPLYING A UNIFORM FEATHERED JOINT AT THIS LOCATION AS PER STANDARD CONSTRUCTION PRACTICES. ALLOW TO DRY AND THEN SAND AS REQUIRED. APPLY ADDITIONAL COATS, AS REQUIRED, TO PROVIDE A UNIFORM AND NEAT FINISH. APPLY THE PROCEDURE TO ANY "CLOSURE" CAPS USED ON PARTIAL HEIGHT INSTALLATIONS.
6. FINISH WALL SURFACE AS SPECIFIED. BE SURE THAT THE SELECTED FINISH IS APPLIED TO THE INSIDE SURFACE OF THE REAR "CONTOURED" PORTION OF THE ALUMINUM RETAINER.

NOTE: ON MODEL SFS-10N: APPLY NEOPRENE TAPE TO NOSE OF THE RETAINER.

7. FINISH INSTALLATION BY SNAPPING THE ACROVYN COVER ONTO THE RETAINER.

