

## CO-8 & SCO-8 CORNER GUARDS

### PLEASE READ

PLEASE READ THESE INSTRUCTIONS THOROUGHLY PRIOR TO BEGINNING THE CO-8 CORNER GUARD INSTALLATION!

THIS INSTRUCTION SHEET IS INTENDED TO PROVIDE A SPECIFIC GUIDE TO FOLLOW FOR THE INSTALLATION OF THIS CO-8 CORNER GUARD. CONTAINED WITHIN IS THE TECHNICAL INFORMATION AND INSTALLATION TECHNIQUES REQUIRED TO COMPLETE AN EFFICIENT, NEAT AND LONG-LASTING INSTALLATION.

INSPECT ALL MATERIALS FOR DAMAGE OR MISSING PARTS. IF YOU DISCOVER DAMAGED OR MISSING MATERIALS, PLEASE CONTACT CUSTOMER SERVICE ON 1300 272 602.

CO-8 CORNER GUARDS MUST BE INSTALLED IN ACCORDANCE WITH THESE INSTRUCTIONS! FAILURE TO FOLLOW THESE INSTRUCTIONS MAY VOID ANY PRODUCT WARRANTIES AND RESULT IN AN UNSUCCESSFUL INSTALLATION. FOR SPECIFIC QUESTIONS REGARDING THE INSTALLATION OF THIS CO-8 CORNER GUARD PLEASE CALL CUSTOMER SERVICE ON 1300 272 602 OR EMAIL [SALES@C-SGROUP.COM.AU](mailto:SALES@C-SGROUP.COM.AU)

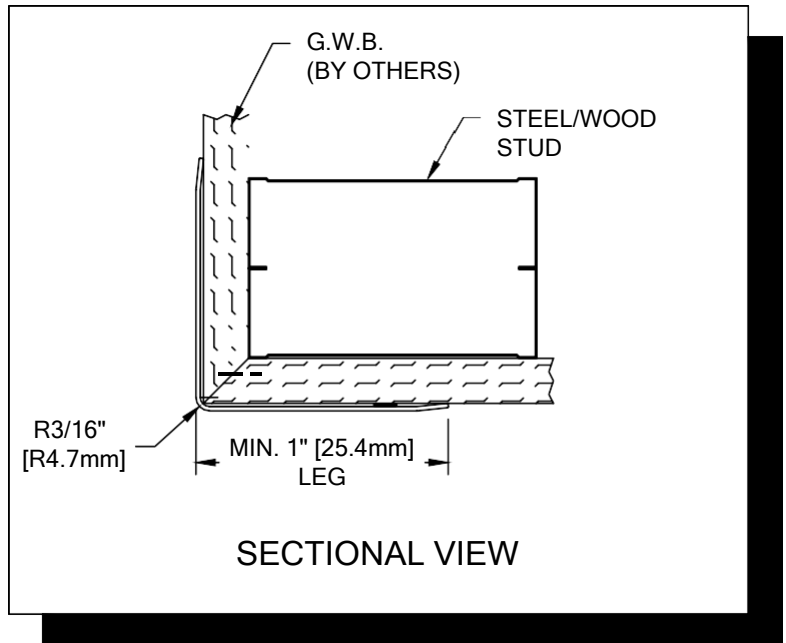

*MODEL: CO-8*

### IMPORTANT NOTES

1. STAINLESS STEEL MATERIAL HAS BEEN MANUFACTURED TO CUSTOMER SPECIFIED DIMENSIONS AND CAN NOT BE CUT OR MODIFIED ON SITE. TO DO SO COULD VOID THE WARRANTY.
2. ALL DIMENSIONS ARE TYPICAL.
3. FOR DRYWALL/PLASTER WALL CONSTRUCTION, IT IS RECOMMENDED FOR FASTENERS TO BE ENGAGED INTO METAL/WOOD STUDS TO MAINTAIN MAXIMUM PULLOUT STRENGTH.
4. MATERIAL MUST REACH 65°F MIN. TO 75°F MAX. 24 HOURS PRIOR TO INSTALLATION. THIS IS ESSENTIAL TO MINIMIZE EXPANSION AND CONTRACTION OF MATERIAL.
5. FOR MORE INFORMATION ON CO-8 AND SCO-8 CORNER GUARDS SEE OUT WEBSITE AT [www.c-sgroup.com.au](http://www.c-sgroup.com.au)

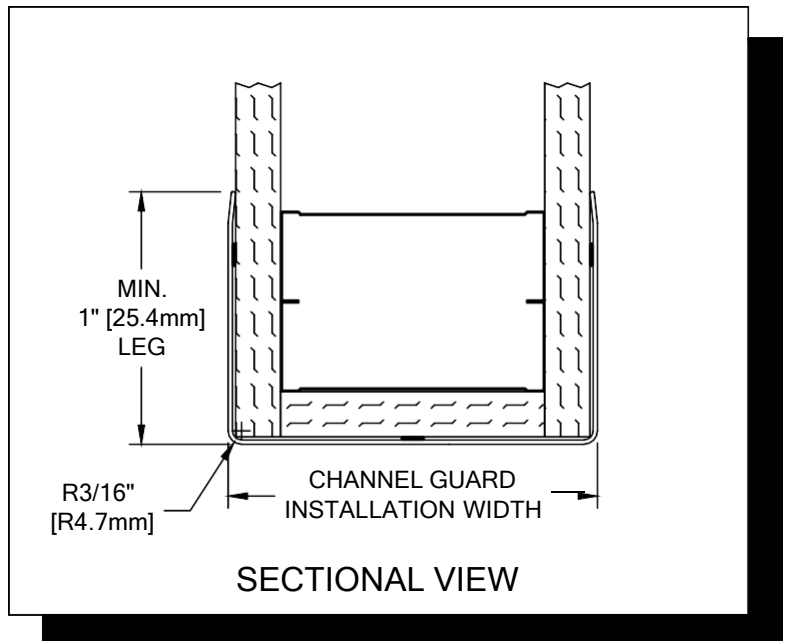

*MODEL: SCO-8*

**CO-8 & SCO-8 CORNER GUARDS**

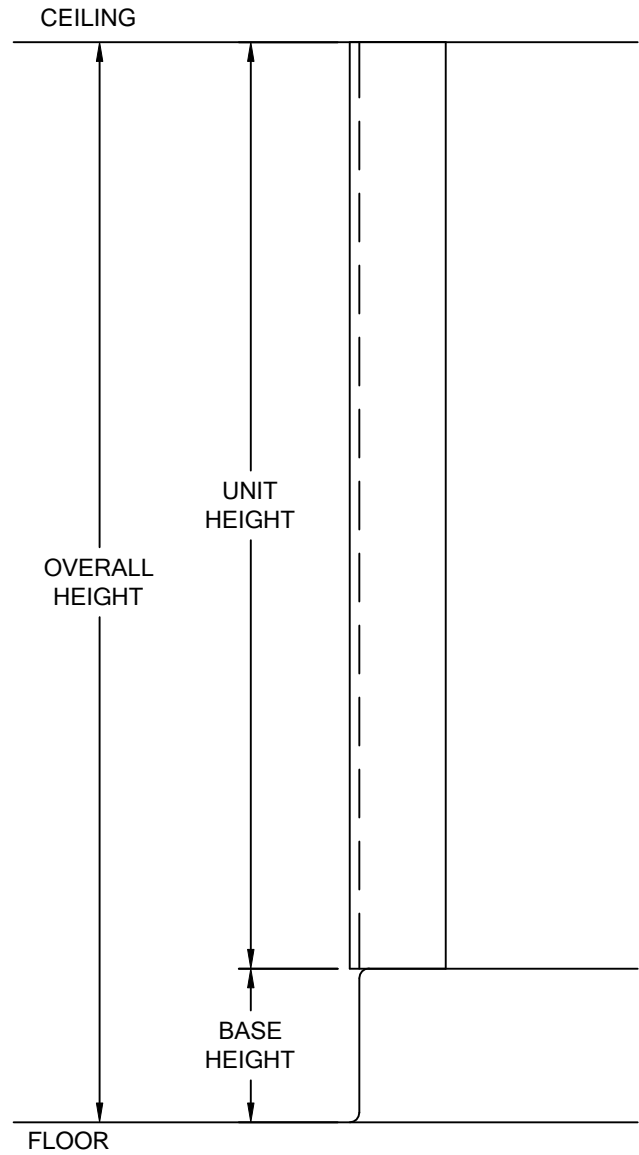
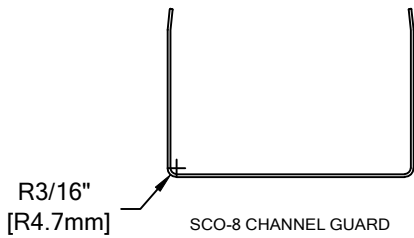
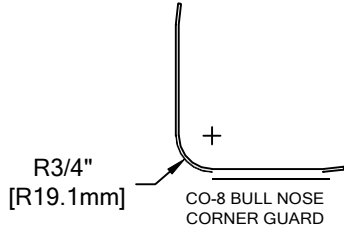
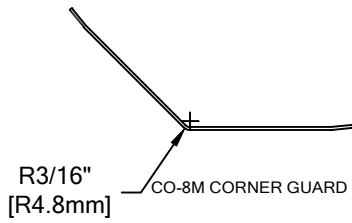
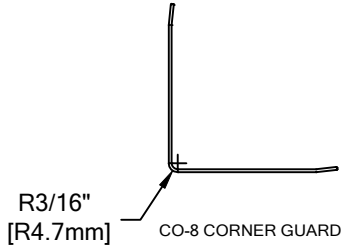

WALL CONDITION	SPECIFIED FASTENER	QUANTITY	CS PART NUMBER
STEEL STUD/GYPSUM WALL CONCRETE/CONC. BLOCK WOOD STUD/GYPSUM WALL	M1 STRUCTURAL ADHESIVE (85 L/F COVERAGE PER TUBE)	28 FL. OZ	90M135001

**CO-8 & SCO-8 CORNER GUARDS**

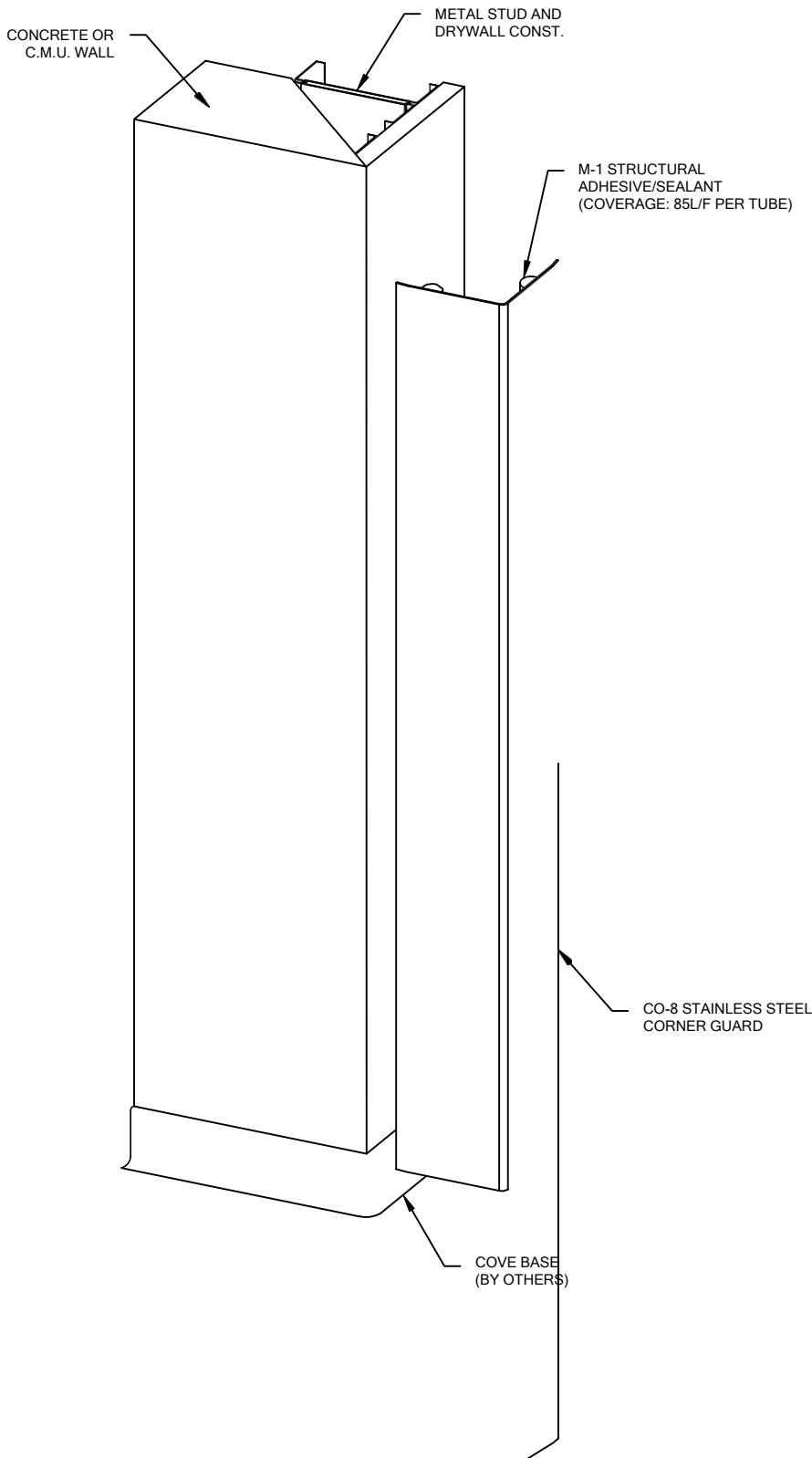

1. LOCATE AND INSTALL CS CORNER GUARDS IN ACCORDANCE WITH ARCHITECTURAL DRAWINGS AND SPECIFICATIONS. WHEN REQUIRED CS SHOP DRAWINGS SHOULD BE USED IN CONJUNCTION WITH THESE DOCUMENTS.
2. PREPARE OUTSIDE CORNER FOR GUARD INSTALLATION BY REMOVING ANY OIL OR DUST USING MILD SOAP AND WATER OR HOUSEHOLD CLEANERS SUCH AS FANTASTIC®, FORMULA 409® OR SIMILAR PRODUCTS.
3. APPLY A 1/4" BEAD OF ADHESIVE TO THE BACKSIDE OF EACH LEG IN A ZIG-ZAG PATTERN THE FULL LENGTH OF THE CORNER GUARD. KEEP ADHESIVE ABOUT 3/4" [19.0mm] FROM THE EDGE.

**NOTE:** FOR SCO-8 A BEAD OF ADHESIVE MAY BE APPLIED TO THE REAR OF THE CENTER SECTION OF CHANNEL GUARD IN THE SAME MANNER AS THE LEGS.

4. INSTALL THE CORNER GUARD BY ALIGNING THE BOTTOM OF THE CORNER GUARD WITH THE TOP OF THE COVER BASE OR FINISH FLOOR AND MOVING THE GUARD INTO POSITION ALONG THE APEX OF THE WALL.
5. RUB EACH LEG WITH A CLEAN SOFT CLOTH AND APPLY MEDIUM HAND PRESSURE TO ENSURE MAXIMUM ADHESION TO THE WALL SURFACE.
6. REMOVE THE PROTECTIVE FILM FROM THE CORNER GUARD.