

EDGING PLEAT HARD ANODISED ALUMINIUM

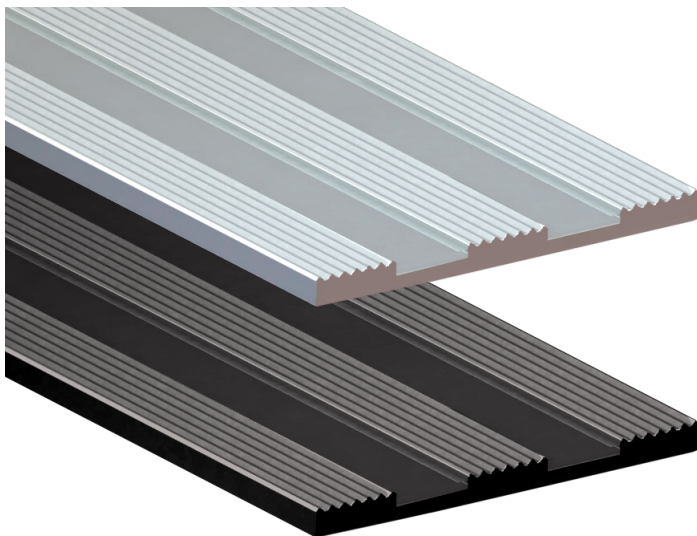

TYPE	Edging
RANGE	Designer Stair Edging
DESIGN	Pleat
MATERIAL	6063 T5 extruded aluminium alloy
FINISH	Hard anodised



FEATURES

Extruded intermittent smooth plates encased between a continuous corduroy pattern designed by DTAC in Australia

Available in exclusive premium quality flat, angle or carpet profiles

Suitable for all stable finished indoor or outdoor surfaces and substrates

Designed to comply with AS 1428.1 Design for Access and Mobility Part 1: General Requirements for Access — New Building Work

Tested for compliance with slip resistance requirements as detailed in HB 198

Backed by 2 year warranty

NCC COMPLIANT

National Construction Code (NCC) compliant products are designed to comply with the NCC—and Disability (Access to Premises—Buildings) Standards to meet the deemed-to-satisfy-provisions

SLIP RESISTANCE TESTING

Important information: To determine a classification of a slip resistance rating, see Australian Standards Hand Book 198 (HB 198), an Introductory Guide to Slip Resistance of Pedestrian Materials. This document outlines the minimum ratings of a location and situation of a pedestrian surface.

TEST Wet Pendulum Test — AS 4586 APPENDIX A

FOUR S 96 SLIDER = 64 **CLASS** = P5

TRL 55 SLIDER = 50 **CLASS** = P4

TEST Dry Floor Friction Test — AS 4586 APPENDIX B

MEAN COF = 0.50 **CLASS** = D1

TEST Wet/Barefoot Ramp Test — AS 4586 APPENDIX C

MEAN ANGLE OF INCLINATION = 28° **CLASS** = C

TEST Oil/Wet Ramp Test — AS 4586 APPENDIX D

CORRECTED MEAN OVERALL ACCEPTANCE ANGLE = 27.2° **CLASS** = R12

LUMINANCE TESTING

Important information: To determine a luminance contrast between a substrate and the DTAC EDGING, see: AS 1428.1:2009. DTAC can test your substrate for luminance contrast to give you peace of mind that your DTAC project will be fully compliant to AS 1428.1.

TEST Design for Access & Mobility — AS 1428.1 APPENDIX B

NATURAL

LUMINANCE REFLECTANCE RATING / WET = 57.8

LUMINANCE REFLECTANCE RATING / DRY = 58.2

BLACK

LUMINANCE REFLECTANCE RATING / WET = 4.4

LUMINANCE REFLECTANCE RATING / DRY = 5.4

DTAC PTY LTD
ABN 41 093 070 127

PEMKO®

Unit 4, 11-12 Phillip Court
Port Melbourne Victoria
Australia 3207

T 1300 793 478
F 1300 780 628

PO Box 5059
South Melbourne Victoria
Australia 3205

estimating@dtac.com.au
www.dtac.com.au

© DTAC Pty Ltd 2017

EDGING PLEAT FINISHES & SIZES

DESIGNER STAIR EDGING - AVAILABLE SIZES

HARD NATURAL ANODISED

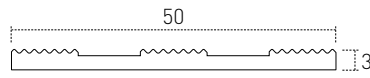

CODE DE0300C

SIZE W50 x T3 - L2500

NCC COMPLIANT

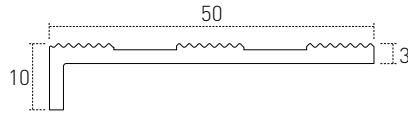

CODE DE0310C

SIZE H10 x W50 x T3 - L2500

NCC COMPLIANT

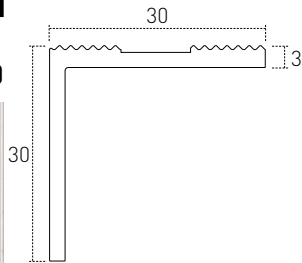

CODE DE0320C

SIZE H30 x W30 x T3 - L2500

NCC COMPLIANT

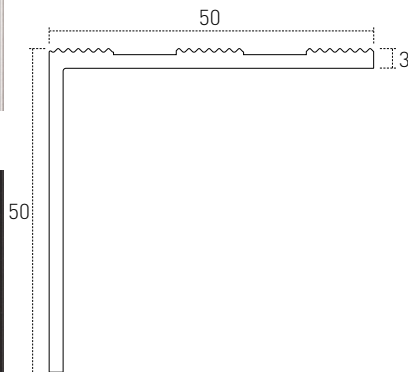

CODE DE0330C

SIZE H50 x W50 x T3 - L2500

NCC COMPLIANT

HARD BLACK ANODISED



CODE DE0300B

SIZE W50 x T3 - L2500

NCC COMPLIANT



CODE DE0310B

SIZE H10 x W50 x T3 - L2500

NCC COMPLIANT

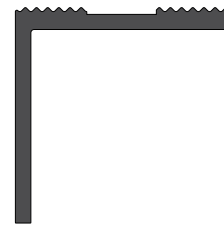

CODE DE0320B

SIZE H30 x W30 x T3 - L2500

NCC COMPLIANT

AVAILABLE FINISHES

HARD NATURAL ANODISED (25µm)



HARD BLACK ANODISED (40µm)



STAIR EDGING SYSTEMS FOR CARPET - AVAILABLE SIZES

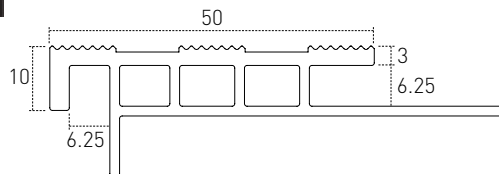

DTAC Registered Design

CODE DE0650C

SIZE H10 x W50 x T3 - L2500

Accepts carpet thickness of 6-10mm - carpet rebate 6.25mm

Colour matched escutcheon plates available for stairs with exposed ends

NCC COMPLIANT

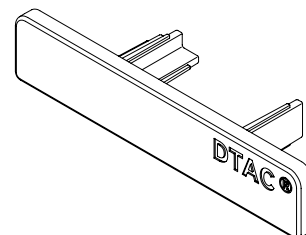

Escutcheon Plate

CODE DESC01

SIZE H10 x W50 x T2.5

EDGING PLEAT INSTALLATION & APPLICATION

SUBSTRATE Stone / Masonry / Timber / Vinyl

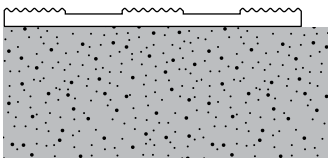

FIXING Adhesive

NCC COMPLIANT

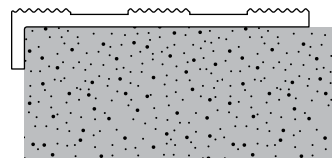

FIXING Adhesive

NCC COMPLIANT

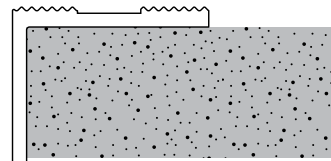

FIXING Adhesive

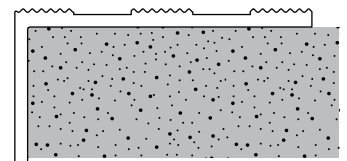

FIXING Adhesive

SUBSTRATE Vitrified Porcelain / Ceramics / Glass / Metals

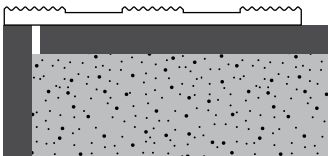

FIXING Adhesive

NOTE Ensure grout line is discrete as illustrated

NCC COMPLIANT

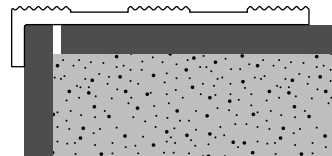

FIXING Adhesive

NOTE Ensure grout line is discrete as illustrated

NCC COMPLIANT

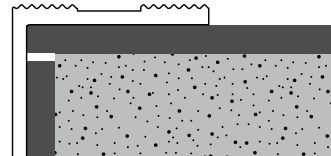

FIXING Adhesive

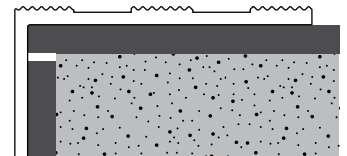

FIXING Adhesive

SUBSTRATE Carpet / Carpet Tiles

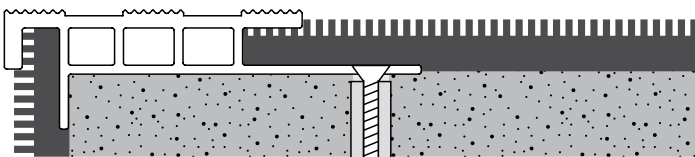

FIXING Screw-fixed or adhesive (screws and plugs supplied)

NOTE DTAC screw-fix mounting methods are available on request

NCC COMPLIANT