

**CO-8 & SCO-8 CORNER GUARDS
WITH S/S FASTENERS**

PLEASE READ

PLEASE READ THESE INSTRUCTIONS THOROUGHLY PRIOR TO BEGINNING THE CO-8 CORNER GUARD INSTALLATION!

THIS INSTRUCTION SHEET IS INTENDED TO PROVIDE A SPECIFIC GUIDE TO FOLLOW FOR THE INSTALLATION OF THIS CO-8 CORNER GUARD. CONTAINED WITHIN IS THE TECHNICAL INFORMATION AND INSTALLATION TECHNIQUES REQUIRED TO COMPLETE AN EFFICIENT, NEAT AND LONG-LASTING INSTALLATION.

INSPECT ALL MATERIALS FOR DAMAGE OR MISSING PARTS. IF YOU DISCOVER DAMAGED OR MISSING MATERIALS, PLEASE NOTIFY CUSTOMER SERVICE ON 1300 272 602.

CO-8 CORNER GUARDS MUST BE INSTALLED IN ACCORDANCE WITH THESE INSTRUCTIONS! FAILURE TO FOLLOW THESE INSTRUCTIONS MAY VOID ANY PRODUCT WARRANTIES AND RESULT IN AN UNSUCCESSFUL INSTALLATION. FOR SPECIFIC QUESTIONS REGARDING THE INSTALLATION OF THIS CO-8 CORNER GUARD PLEASE CALL CUSTOMER SERVICE ON 1300 272 602 OR EMAIL SALES@C-SGROUP.COM.AU

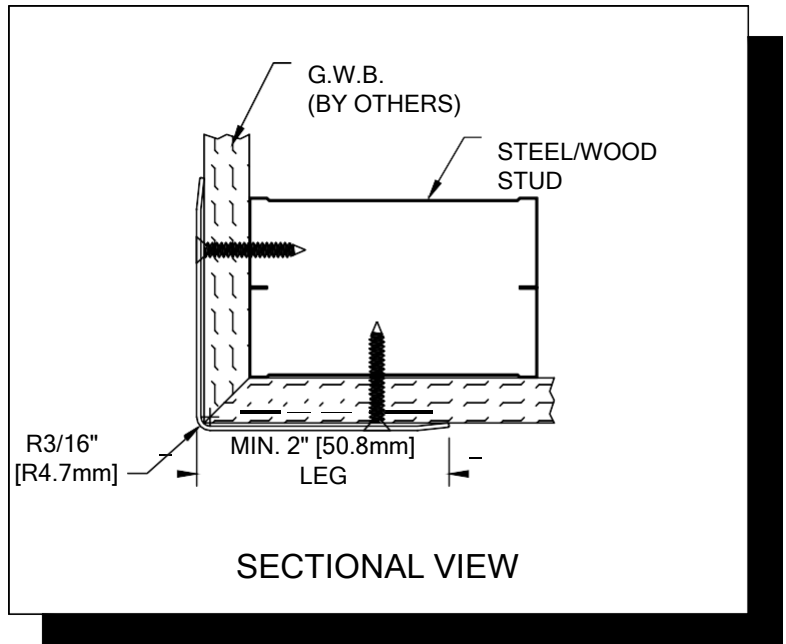

MODEL: CO-8

IMPORTANT NOTES

1. STAINLESS STEEL MATERIAL HAS BEEN MANUFACTURED TO CUSTOMER SPECIFIED DIMENSIONS AND CAN NOT BE CUT OR MODIFIED ON SITE. TO DO SO COULD VOID THE WARRANTY.
2. ALL DIMENSIONS ARE TYPICAL.
3. FOR DRYWALL/PLASTER WALL CONSTRUCTION, IT IS RECOMMENDED FOR FASTENERS TO BE ENGAGED INTO METAL/WOOD STUDS TO MAINTAIN MAXIMUM PULLOUT STRENGTH.
4. MATERIAL MUST REACH 65°F MIN. TO 75°F MAX. 24 HOURS PRIOR TO INSTALLATION. THIS IS ESSENTIAL TO MINIMIZE EXPANSION AND CONTRACTION OF MATERIAL.
5. FOR MORE INFORMATION ON CO-8 AND SCO-8 CORNER GUARDS SEE OUT WEBSITE AT www.c-sgroup.com.au

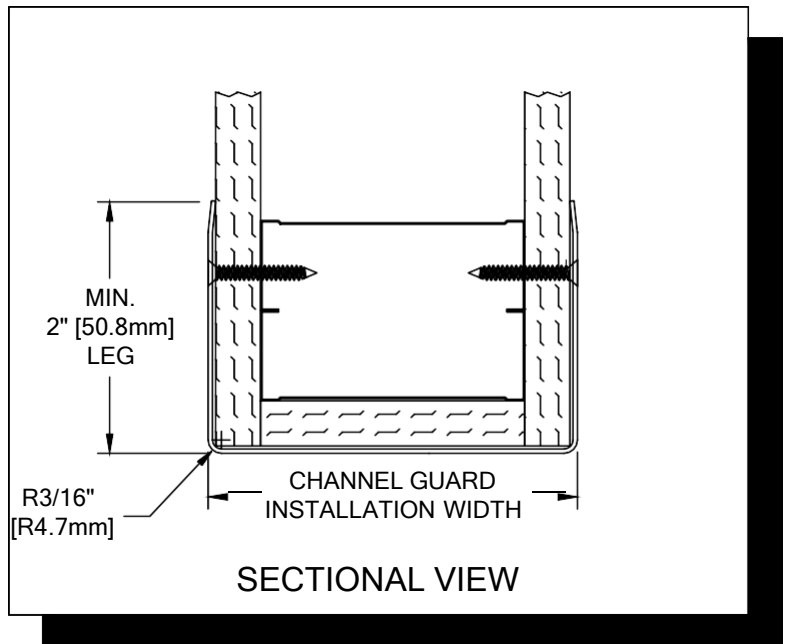

MODEL: SCO-8

**CO-8 & SCO-8 CORNER GUARDS
WITH S/S FASTENERS**

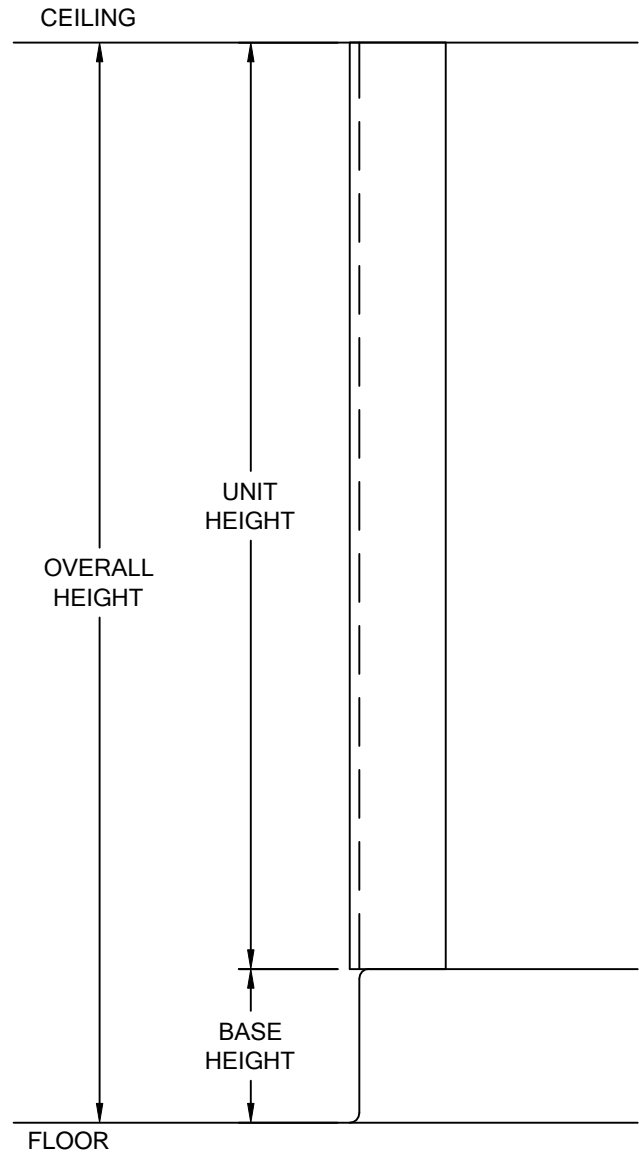
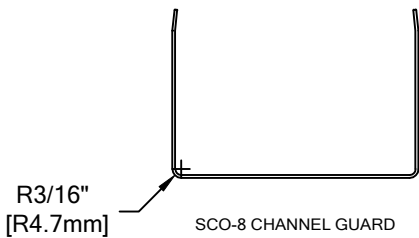
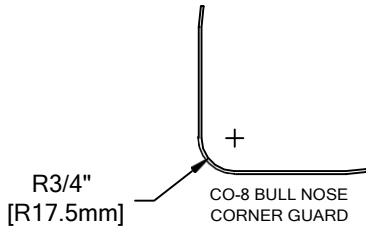
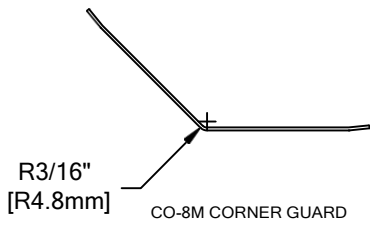
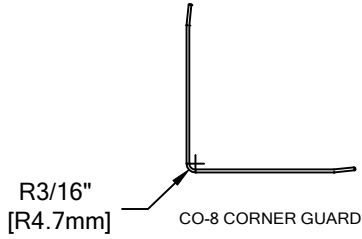

WALL CONDITION	SPECIFIED FASTENER	DRILL DIAMETERS		CS PART NUMBER
		WALL	RETAINER	
CONCRETE/CONCRETE BLOCK	#10 X 1 1/2" S/S PHILLIPS FLAT HEAD WOOD SCREW AF-8 PLASTIC ANCHORS	1/4"	N/A	90H009002 90H049004
STEEL STUD/GYPSUM WALL	#10 X 1 1/2" S/S PHILLIPS FLAT HEAD WOOD SCREW	N/A	N/A	90H009002
WOOD STUD/GYPSUM WALL	#10 X 1 1/2" S/S PHILLIPS FLAT HEAD WOOD SCREW	N/A	N/A	90H009002

**CO-8 & SCO-8 CORNER GUARDS
WITH S/S FASTENERS**

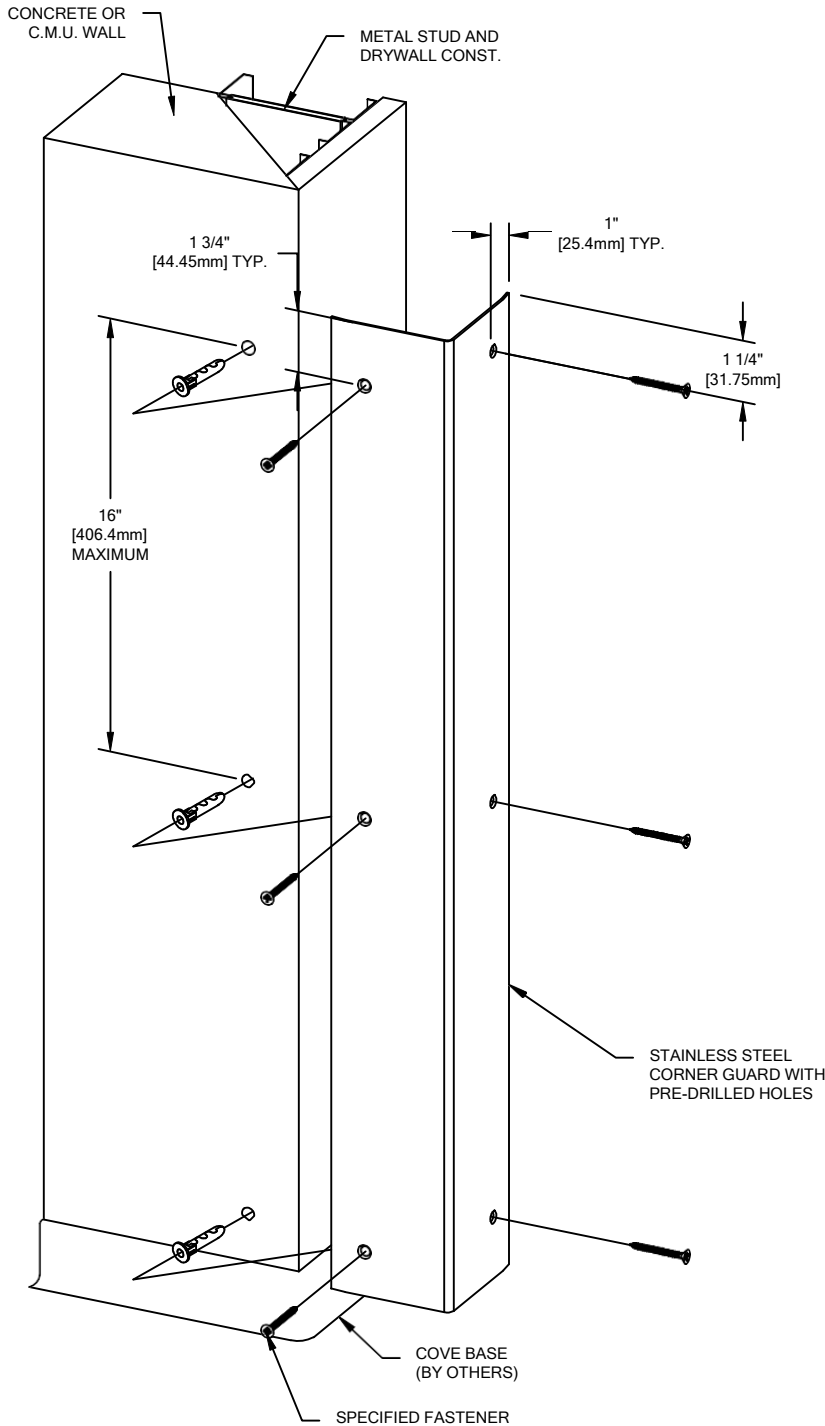

1. LOCATE AND INSTALL CS CORNER GUARDS IN ACCORDANCE WITH ARCHITECTURAL DRAWINGS AND SPECIFICATIONS. WHEN REQUIRED CS SHOP DRAWINGS SHOULD BE USED IN CONJUNCTION WITH THESE DOCUMENTS.
2. LAY OUT THE WORK TO BE COMPLETED, INCLUDING COMPONENT PARTS, AT EACH LOCATION TO RECEIVE CORNER GUARDS AS INDICATED BY THE CS SHOP DRAWINGS. SPOT CHECK THE MATERIAL FOR ANY DAMAGE INCURRED DURING SHIPPING AND/OR HANDLING AT THE JOB SITE.
3. ESTABLISH CORNER GUARD HEIGHT REQUIREMENT.
4. INSTALL THE CORNER GUARD BY ALIGNING THE BOTTOM OF THE CORNER GUARD WITH THE TOP OF THE COVE BASE OR FINISH FLOOR AND MOVING THE GUARD INTO POSITION ALONG THE APEX OF THE WALL SURFACE.
5. COMPLETE INSTALLATION BY SECURING THE CORNER GUARD INTO POSITION USING THE APPROPRIATE FASTENERS.
6. REMOVE THE PROTECTIVE FILM FROM THE CORNER GUARD.